

# SELSAT

## SELSAT-ROTOR HH90



ENGLISH

DEUTSCH

ITALIANO

FRANÇAIS

ESPAÑOL



**INSTRUCTIONS MANUAL  
BEDIENUNGSANLEITUNG  
MANUALE D'ISTRUZIONE  
MODE D'EMPLOI  
MANUAL DE INSTRUCCIONES**

**We guarantee the complete compability and the perfect working in USALS® mode only with receivers which carry this logo:**



## Rotor technical data

Communication protocol	DiSeqC1.2® Level	Operating temperature	-40°C +80°C
Maximum dish diameter	95 cm	Maximum relative humidity	100%
Maximum dish weight	10 Kg	Programmable positions (DiSeqC1.2®)	49 satellites
Diameter of support pole	ø (35 to 68) mm	Preset positions (DiSeqC1.2®)	28 satellites
Dish support length	145 mm	Programmable positions (USALS®)	no limits
Dish support diameter	ø 42 mm	Connectors	F type
Rotation angle	±65°	Connection	Coaxial cable
Rotation speed	2,4°/s (18V) 1,5°/s (13V)	Mechanical limits	±72°
Operating power supply	13/18 Vdc	Programmable electrical limits	from 5° to 65°
Consumption in stand-by mode	40 mA	Fine rotation	by impulses of 0,1°
Consumption in operating mode	180 mA	Inclination of the rotor on the pole	from 10° to 70°
Starting movement consumption (max)	350 mA	Rotor weight	2,6 kg

## Accessories for rotor assembly

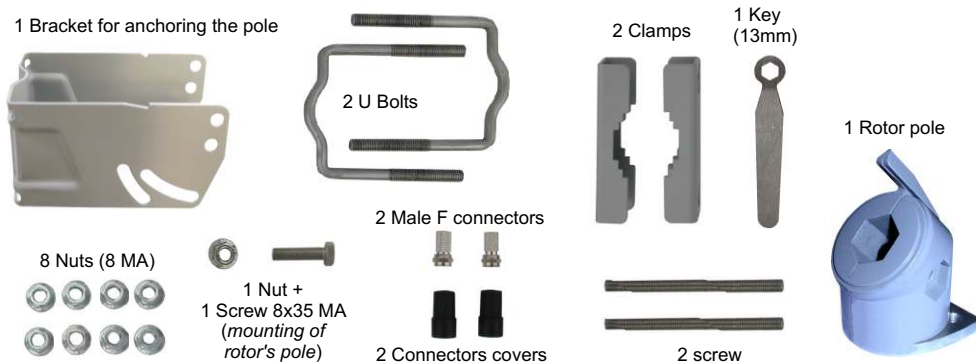

## Accessories for antenna assembly

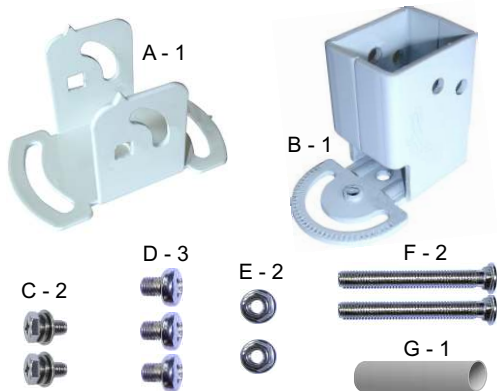

## Antenna

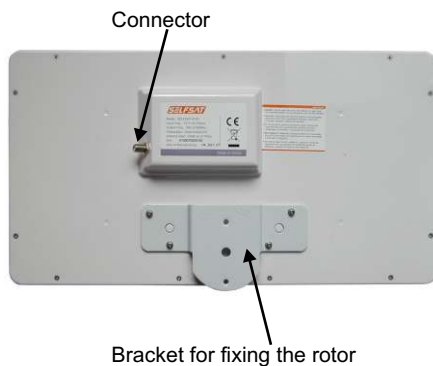

The USALS installation procedure is extremely simple. If you are not absolutely certain of the coordinates and the degrees of elevation of the antenna for your installation location, consult the site: [www.stab-usals.us](http://www.stab-usals.us) or the maps at pages 27-35. STAB will provide you with all the data of: **Latitude**, **Longitude**, **Dish Elevation**.

**1**

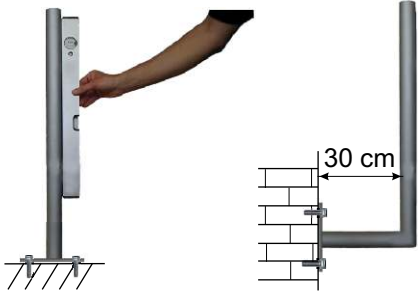

In order to obtain a correct pointing of the satellites, all system must be in a perfect plumb line.

**2**

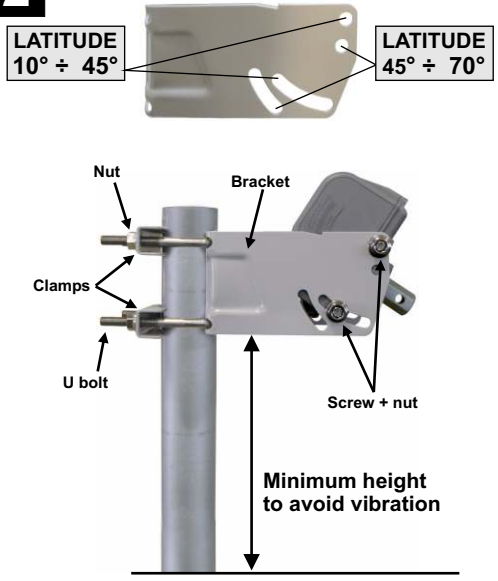

**3**

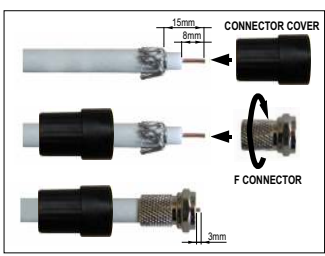

- On a coaxial cable approximately 1,5 m long, set up 2 F-connectors.
- Connect the antenna to the rotor's LNB plug.
- Fit an F-connector on each end of the cable going to the receiver and connect the rotor's REC plug to the plug of the receiver.

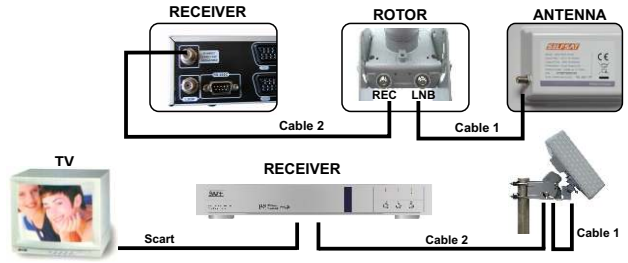
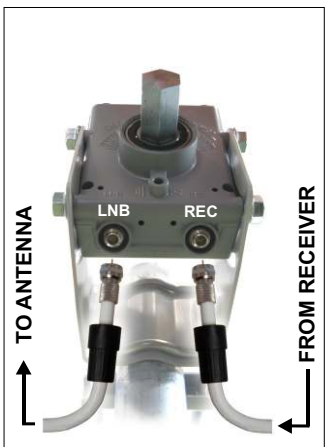

**Characteristics of the coaxial cable**

**LENGTH: up to 30 m**

**LENGTH: from 30 m to 60 m**

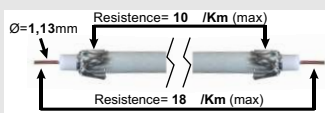
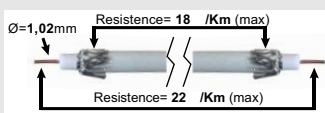

4

LATITUDE from 10° to 45°

LATITUDE from 45° to 70°

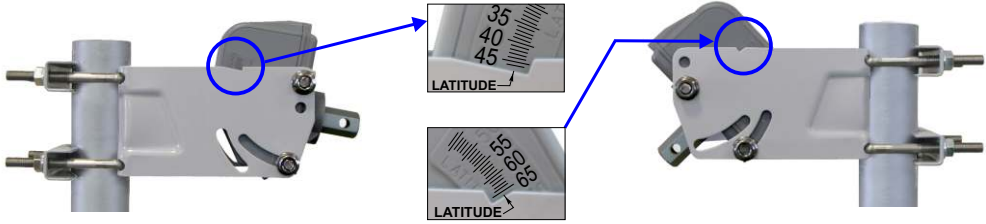

Align the rotor inclination to your **LATITUDE** and tighten the fixing screw.

5

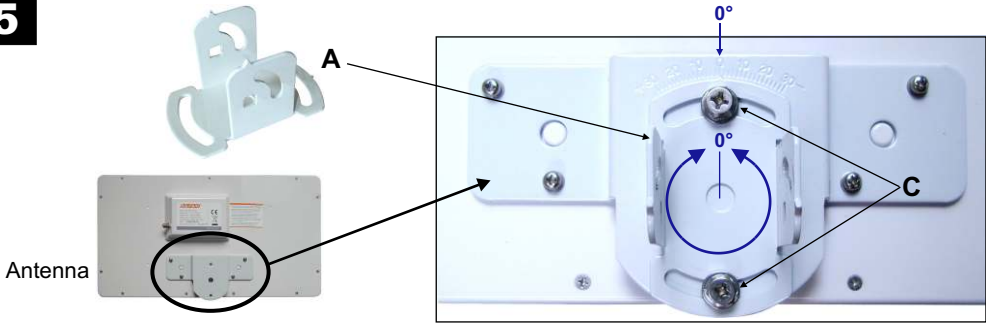

Antenna

6

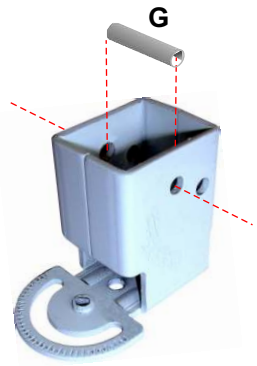

7

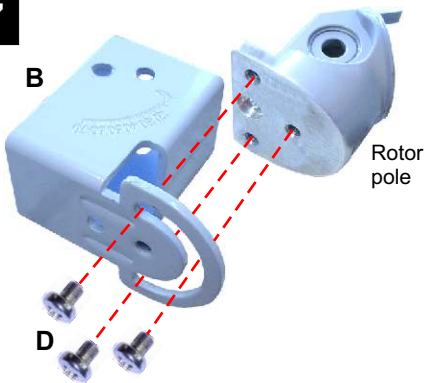

8

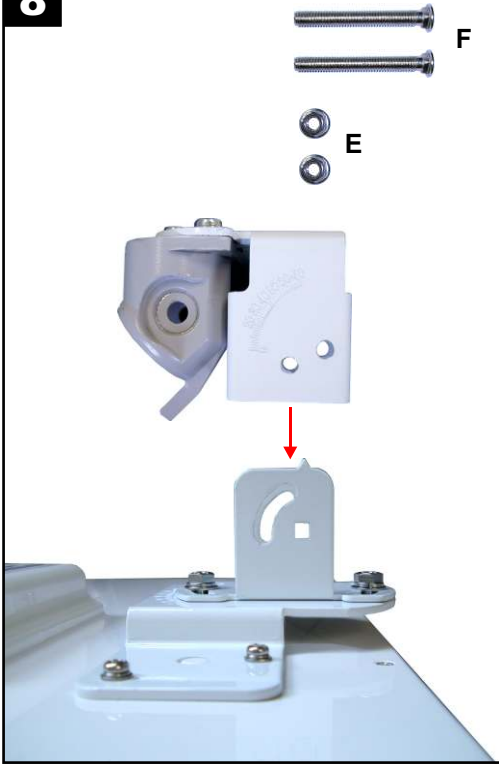

**9** Adjust the antenna inclination according to the **DISH ELEVATION** value obtained from the maps on pages 27-35. If you are going to adjust the motor according to the value received by [www.stab-usals.us](http://www.stab-usals.us), please add 3 degrees to the elevation value for HH90 motor.

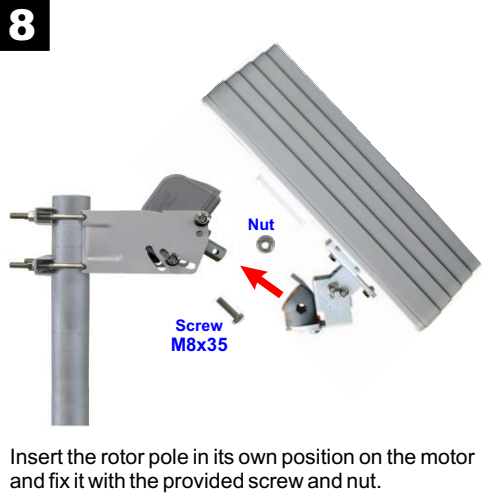
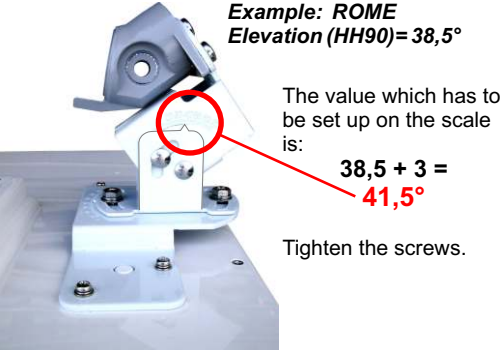

**10** - See your receiver's instructions manual and select the type of installation in USALS® mode.

**Antenna setup**

HotBird 13E	Motor Setting	USALS
(1) 10,719 GHz	Move	Stop
Vertical - 14V	Go to Reference	Go to 0
27,500MSPS	My Longitude	012,5 E
Tuner Lock	My Latitude	41,9 N
FEC 3/4		
Level		
Quality		

**USALS positioner in use**

- Choose a satellite the nearest to your SOUTH (if you lie in the northern hemisphere) or NORTH (if you lie in the southern hemisphere).

**EX: ROMA, LONGITUDE 12,5°E nearest satellite, HOTBIRD 13,0°E**

- Fill in the empty spaces in the receiver's menu with the **LATITUDE** and **LONGITUDE** value previously provided by the web site: [www.stab-usals.us](http://www.stab-usals.us) or by the maps on pages 27-35.

**EX: ROMA, LATITUDE 41,9°N LONGITUDE 12,5°E**

When the value have been correctly received, the receiver drives the motor to the calculated position.



Wait until the motor stops. Slightly rotate clockwise or anticlockwise the dish and the motor locked together until you find an image on the TV screen.

**12**

**Antenna setup**

HotBird 13E	Motor Setting	USALS
(1) 10,719 GHz	Move	Stop
Vertical - 14V	Go to Reference	Go to 0
27,500MSPS	My Longitude	012,5 E
Tuner Lock	My Latitude	41,9 N
FEC 3/4		
Level 87%		
Quality 76%		

**USALS positioner in use**

When the **signal quality** reaches the top value, tighten the motor screws to the supporting pole. Installation is now finalized.

## Warning

- Only a specialist can guarantee a correct mechanical installation which will avoid damage or serious injury.
- The motor must not be mounted upside-down.
- For mounting, all the screws and nuts contained in the kit must be used. The absence of one screw or nut may cause instability or the fall of the equipment.
- The motor has been tested for resistance in wind conditions of 140 Km/h with a dish of 100 cm, so care must be taken in choosing the supporting pole and its anchorage. If possible, installation should be carried out in a place sheltered from wind (rooftops are never advisable).
- The use of dishes with a larger diameter than that indicated in the specifications for each motor is strictly prohibited.
- The motor, being a mechanical rotating instrument, must be installed out of reach of people.
- The motor must not be used for purposes other than those indicated by STAB.
- The motor has been designed to be supplied by a sat receiver or by a STAB positioner; any other type of supply is strictly prohibited and may cause damage or serious injury.
- Some receivers have an anti-disturbance system linked to the body of the connector F. This may provoke a slight electric shock not dangerous for the user. In particular conditions (e.g. on a roof or on a staircase) it may cause falls or injuries. Each time the motor is handled the receiver must be disconnected from the outlet.

## Warranty conditions

This rotor is produced and tested by our laboratory with extreme care and carries a warranty for 36 months from purchase date. A copy of the shop receipt or the invoice represent the warranty document and must be sent together with the set when returned. This warranty covers all production defects and working faults, but excludes all damages caused by drops, incorrect use or external oxidations due to incorrect installation. Any repair made by unauthorised personnel will automatically cancel this warranty.

**PLEASE FILL IN THIS FORM WITH THE SERIAL NUMBER OF THE MOTOR IN CASE OF AFTER SALES OR TECHNICAL ASSISTENCE.**

SERIAL NUMBER							

## Information

For further information and advice about installation and uses contact:

YOUR LOCAL DEALER or:

IDOIT

Midi France Distribution ZA de Fontvieille Route des 4 Saisons

13190 ALLAUCH - FRANCE

Tel: +33 - (0)4 91 07 50 50

[selsat@mfdis.com](mailto:selsat@mfdis.com)

**Wir garantieren die vollständige Kompatibilität und das einwandfreie Funktionieren im USALS®-Betrieb nur bei Receivern mit diesem Logo:**



## Technische Daten

Kommunikationsprotokoll	DiSEqC1.2® Level	Betriebstemperatur	-40°C +80°C
Max. Antennendurchmesser	95 cm	Max. rel. Luftfeuchtigkeit	100%
Max. Antennengewicht	10 kg	Programmierbare Positionen (DiSEqC1.2®)	49 Satelliten
Durchmesser des Stützmasten	∅ (35 bis 68) mm	Voreingestellte Positionen (DiSEqC1.2®)	28 Satelliten
Länge der Antennenstütze	145 mm	Programmierbare Positionen (USALS®)	Keine Begrenzungen
Durchmesser der Antennenstütze	∅ 42 mm	Anschlüsse	F-Type
Rotationswinkel	±65°	Anschlussart	Koaxialkabel
Rotationsgeschwindigkeit	2,4°/s (18V) 1,5°/s (13V)	Mechanische Begrenzung	±72°
Betriebsstromversorgung	13/18 Vdc	Programmierbare elektrische Begrenzung	von 5° bis 65°
Stromverbrauch Standby	40 mA	Feinbewegung	Impulse; 0,1°-Schritte
Stromverbrauch Betrieb	180 mA	Neigung des Rotors am Mast	von 10° bis 70°
Max. Stromverbrauch bei Bewegungsstart	350 mA	Rotorgewicht	2,6 kg

## Zubehörteile für den Motorzusammenbau

1 Klammer für den Masten



2 U-Bolzen

2 Klemmschraube



1 Schlüssel (13mm)



1 Rotorauflage



2 F-Anschlüsse (männlich)



8 Muttern (8 MA)



1 Mutter +  
1 Schraube (M8x35)  
(Für den montage  
Der Rotorauflage)

2 Anschlussabdeckung



2 Schrauben



## Zubehörteile für den Antennenzusammenbau



A - 1



B - 1

C - 2



D - 3



E - 2



F - 2



G - 1



## Antenne





Die Installation mit USALS® ist äußerst einfach. Wenn Sie sich nicht 100% sicher sind, die richtigen Koordinaten und den Elevationswinkel der Antenne zu haben, dann sehen Sie einfach auf der Website [www.stab-usals.us](http://www.stab-usals.us) oder auf der Karte auf den Seiten 27-35 nach.

STAB liefert Ihnen alle Daten für: **Breitengrad, Längengrad, Antennenelevation**

**1**

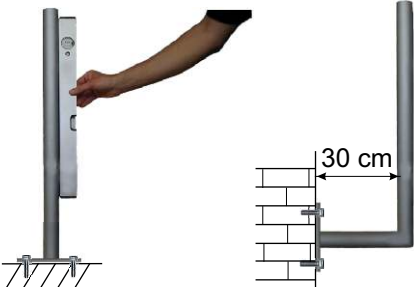

Um eine korrekte Ausrichtung auf die Satelliten sicher zu stellen, müssen alle Systeme genau im Lot aufgestellt sein.

**2**

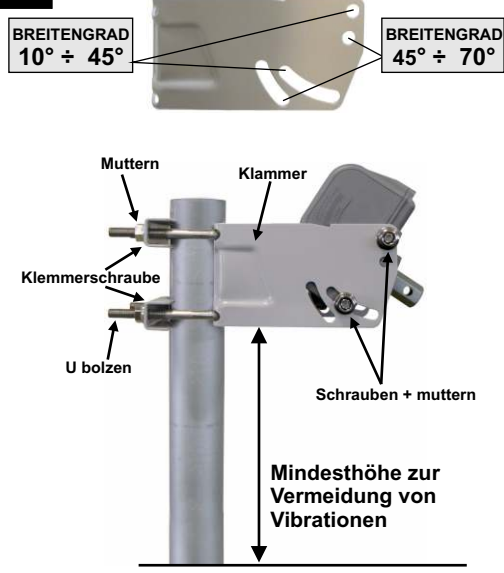

**3**

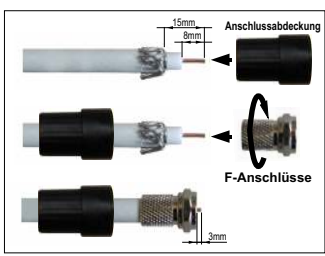

- Bringen Sie an einem ungefähr 1,5m langen Koaxialkabel zwei F-Stecker an.
- Verbinden Sie die Antenne mit dem Antennenanschluss des Rotors.
- Bringen Sie an dem zum Receiver führenden Kabel ebenfalls zwei F-Stecker an und verbinden Sie den REC-Anschluss des Rotors mit dem Anschluss Ihres Receivers.

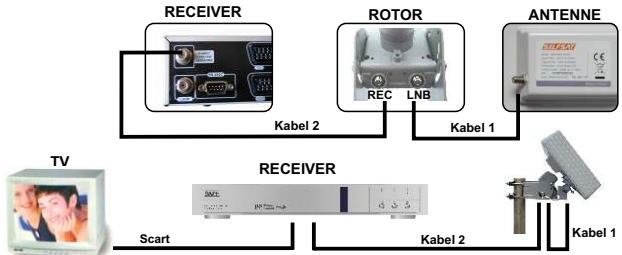
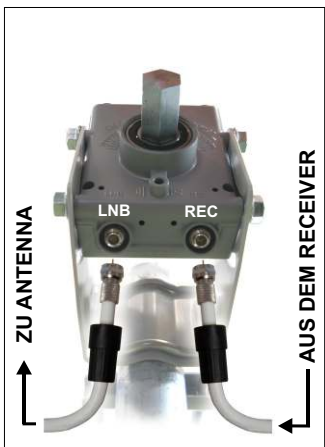

**Eigenschaften des Koaxialkabels**

**Kabellänge: bis 30 m**

**Kabellänge: von 30 m bis 60 m**

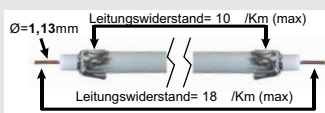
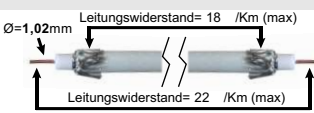

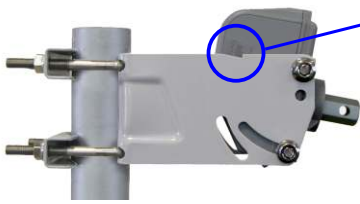
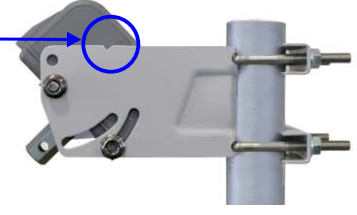

**4****BREITENGRAD  
VON 10° BIS 45°****BREITENGRAD  
VON 45° BIS 70°**

Passen Sie die Rotorneigung an Ihren **Breitengrad** an und ziehen Sie die Befestigungsschrauben fest.

**5**

Antenne

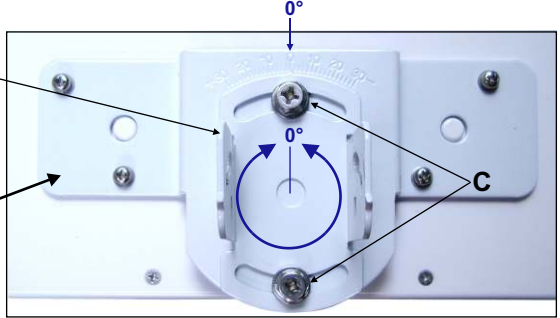
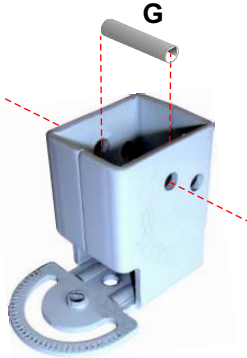
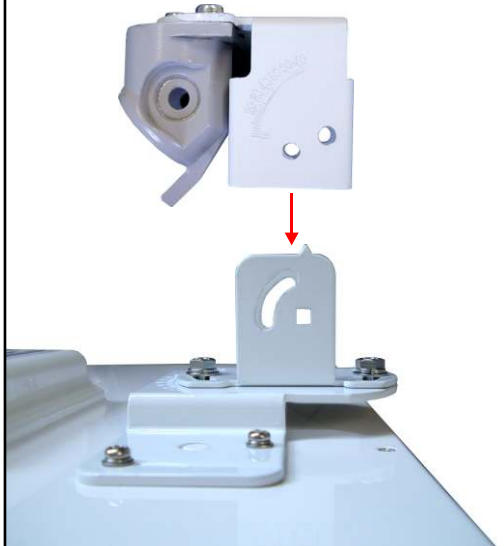
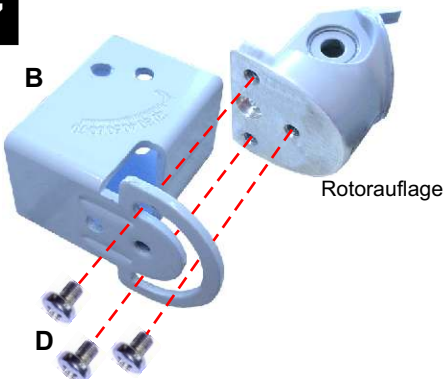
**6****8****7**

Rotorauslage

**9** Passen Sie die Antennenneigung am **Antennenelevationswert** an, der von den Karten auf den Seiten 27-35 herausgeholt worden ist.

Wenn Sie den Motor gemäß dem Wert beim [www.stab-usals.us](http://www.stab-usals.us) installieren wollen, bitte addieren Sie 3 Grade dem Elevationswert für den HH90-Motor.

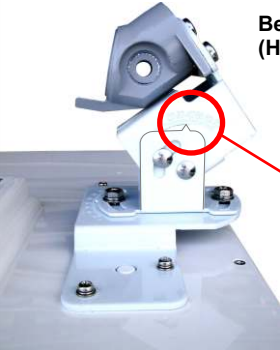

**Beispiel: ROM Elevation (HH90) = 38,5°**

Der Wert, den man am Klammergradmesser anlegen soll, ist:

$$38,5 + 3 = 41,5^\circ$$

Ziehen Sie die Befestigungsschraube an.

**8**

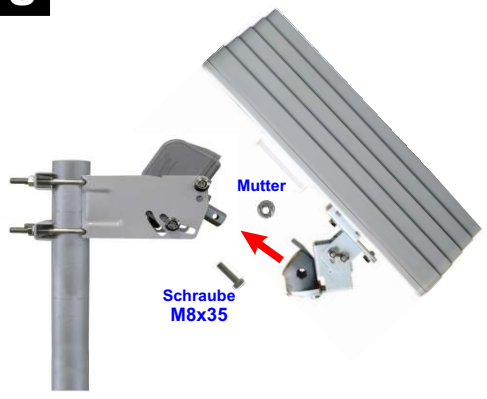

Schieben Sie das Rohr in seine Position am Motor und befestigen Sie es mit den mitgelieferten Schraube und Mutter.

**10**

- Beziehen Sie sich auf die Bedienungsanleitung Ihres Receivers und wählen Sie die **USALS-Installation**.

**Antenna setup**

<b>HotBird 13E</b>	Motor Setting	<b>USALS</b>
(1) 10,719 GHz	Move	Stop
Vertical - 14V	Go to Reference	Go to 0
27,500MSPS	My Longitude	<b>012,5 E</b>
Tuner Lock	My Latitude	<b>41,9 N</b>
FEC 3/4		
Level		
Quality		

**USALS positioner in use**

- Wählen Sie einen Satelliten, der so südlich wie möglich liegt, wenn Sie in der nördlichen Hemisphäre leben, bzw. der so nördlich wie möglich liegt, wenn Sie in der südlichen Hemisphäre leben.

**Beispiel: ROM, Längengrad 12,5°E  
Nächster Satellit, HOTBIRD 13,0°E**

- Geben Sie im Eingabefeld des Receivermenüs die Werte für den **Breitengrad** und **Längengrad** ein, den Sie über die Website [www.stab-usals.us](http://www.stab-usals.us) oder die Karten auf den Seiten 27-35 ermittelt haben.

**Beispiel: ROM, Breitengrad 41,9°N  
Längengrad 12,5°E**

Nach erfolgter korrekter Eingabe steuert der Receiver den Motor auf die errechnete Position.

**11**



Warten Sie bis sich der Motor nicht mehr bewegt. Drehen Sie Antenne und den mit ihr verbundenen Motor vorsichtig im oder gegen den Uhrzeigersinn bis Sie ein Bild auf dem an den Receiver angeschlossenen Fernsehgerät sehen können.

**12**

**Antenna setup**

<b>HotBird 13E</b>	Motor Setting	<b>USALS</b>
(1) 10,719 GHz	Move	Stop
Vertical - 14V	Go to Reference	Go to 0
27,500MSPS	My Longitude	<b>012,5 E</b>
Tuner Lock	My Latitude	<b>41,9 N</b>
FEC 3/4		
Level	87%	
Quality	76%	

**USALS positioner in use**

Als die **Empfangsqualität** den höchsten Wert erreicht hat, ziehen Sie die Befestigungsschrauben des Motors dem Mast an. Die Installation wird durchgeführt.

## Warnhinweise

- Nur Fachpersonal kann eine korrekte mechanische Installation sicherstellen, die Schäden bzw. Verletzungen verhindert.
- Eine Installation des Motors in umgekehrter Ausrichtung ist verboten.
- Für die Installation müssen alle mitgelieferten Schrauben und Muttern verwendet werden. Das Nichtverwenden nur einer Schraube oder Mutter kann die Stabilität des Systems gefährden und zu mangelhafter Befestigung führen.
- Der Motor wurde auf Windwiderstand bis 140 km/h getestet, mit einer Satellitenantenne mit 100 cm Durchmesser. Dementsprechend muss ein entsprechender Stützmast verwendet werden, der ausreichend stabil fixiert wird. Falls möglich, sollte ein windgeschützter Aufstellungsort gewählt werden (Dachmontage wird nicht empfohlen).
- Die Verwendung von Satellitenantennen mit einem größeren als für jeden Motor angegebenen Durchmesser ist strengstens verboten.
- Der Motor ist ein mechanischer, beweglicher Bauteil und muss daher außerhalb der Reichweite anderer Personen installiert werden.
- Der Motor darf nur für die von STAB angegebenen Zwecke eingesetzt werden.
- Der Motor wurde für Stromversorgung über einen Satellitenreceiver oder Satellitenpositioner entwickelt. Jede andere Art der Stromzufuhr ist strengstens verboten und kann zu Schäden oder schweren Verletzungen führen.
- Einige Receiver besitzen ein System zur Störungsminimierung, das mit dem Gehäuse des F-Steckers verbunden ist. Dadurch kein ein leichter elektrischer Schlag ausgelöst werden, der für den Anwender absolut ungefährlich ist. Unter besonderen Umständen (z.B. auf dem Dach oder auf einer Stiege) kann dieser Schlag aber einen Sturz oder Verletzungen verursachen. Bei jeder Arbeit am Motor muss der Receiver daher vom Stromnetz getrennt werden.

## Gewährleistungsbestimmungen

Der Rotor wurde mit größter Sorgfalt hergestellt und in unserem Labor getestet und hat eine Garantie von 36 Monaten ab dem Kaufdatum. Eine Kopie des Kaufbeleges oder der Rechnung gilt als Garantienachweis und muss im Garantiefall zusammen mit dem Set eingeschickt werden. Die Gewährleistung umfasst alle Produktions- und Betriebsfehler, schließt jedoch alle Schäden aufgrund von Fallenlassen, unsachgemäßer Benutzung oder externer Oxidation aufgrund unsachgemäßer Installation aus. Bei Reparatur durch Unbefugte erlischt die Garantie automatisch.

**FÜLLEN SIE DIESES FORMBLATT MIT DER SERIENNUMMER DES MOTORAUS, FALLS SIE HANDELS ODER KUNDENDIENST MÖGEN.**

SERIENNUMMER

--	--	--	--	--	--	--	--	--	--

## Information

Bei weiteren Fragen zu Installation oder Betrieb wenden Sie sich bitte an

IHREN FACHHÄNDLER oder

IDOIT

Midi France Distribution ZA de Fontvieille Route des 4 Saisons

13190 ALLAUCH - FRANCE

Tel: +33 - (0)4 91 07 50 50

selfsat@mfdis.com

**Garantiamo la compatibilità ed il perfetto funzionamento in modalità USALS® solo per i ricevitori che hanno stampato il logo:**



## Caratteristiche Tecniche Rotore

Protocollo di comunicazione	DiSEqC1.2®	Temperatura di lavoro	-40°C +80°C
Diametro massimo antenna	95 cm	Umidità relativa massima	1 0 0 %
Peso massimo antenna	10 Kg	Posizioni programmabili (DiSEqC1.2®)	49 satelliti
Diametro palo di supporto	ø (35 a 68) mm	Posizioni pre-programmate (DiSEqC1.2®)	28 satelliti
Lunghezza perno mobile	145 mm	Posizioni programmabili (USALS®)	senza limiti
Diametro perno mobile	ø 42 mm	Connettori	Tipo F
Angolo di rotazione	±65°	Collegamento	Cavo coassiale
Velocità di rotazione	2,4°/s (18V) 1,5°/s (13V)	Limiti meccanici	±72°
Tensione di lavoro	13/18 Vdc	Limiti elettronici programmabili	de 5° a 65°
Assorbimento in stand by	40 mA	Rotazione fine	a impulsi di 0,1°
Assorbimento operativo	180 mA	Inclinazione del rotore sul palo	da 10° a 70°
Assorbimento massimo	350 mA	Peso rotore	2,6 Kg

## Accessori per il montaggio rotore

1 Staffa per ancoraggio al palo



2 Morse



1 Chiave (13mm)



1 Perno di supporto antenna



8 Dadi (8 MA)



1 Dado +  
1 Vite 8x35 MA  
*(per il montaggio  
del perno di supporto)*



2 Connettori F maschio



2 copriconnettori



2 perni filettati



## Accessori per il montaggio dell'antenna

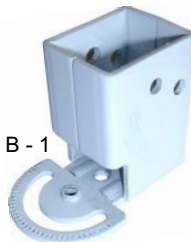

C - 2



D - 3



E - 2



F - 2



G - 1



## Antenna



La procedura d'installazione in modalità USALS è estremamente semplice. Se non siete assolutamente certi delle coordinate e dei gradi di elevazione dell'antenna per il vostro luogo d'installazione, consultare il sito: [www.usals.info](http://www.usals.info), oppure le cartine alle pagine 27-35.

STAB vi fornirà tutti i dati di: **LATITUDINE, LONGITUDINE, ELEVAZIONE ANTENNA**

**1**

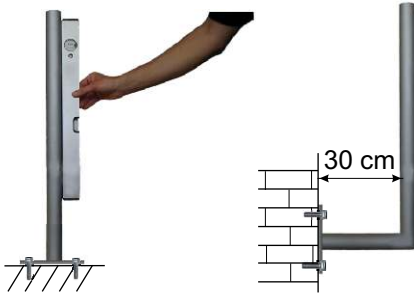

Il palo di sostegno deve essere perfettamente a piombo per avere un corretto puntamento dei satelliti.

**2**

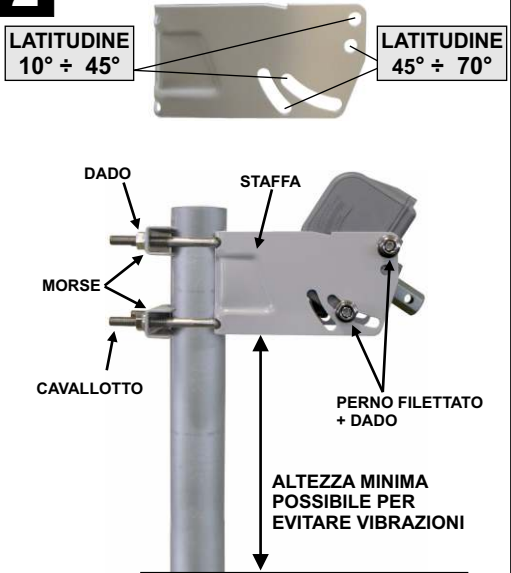

**3**

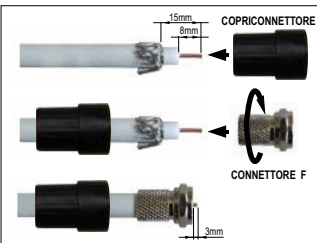

- Preparare un cavo lungo 1,5 m montando i connettori F in dotazione alle estremità (attenersi alle caratteristiche del cavo coassiale, vedi sotto).
- Collegare l'antenna al rotore.
- Montare alle estremità del cavo di discesa i connettori F e collegare l'uscita del rotore (REC) all'ingresso del ricevitore.

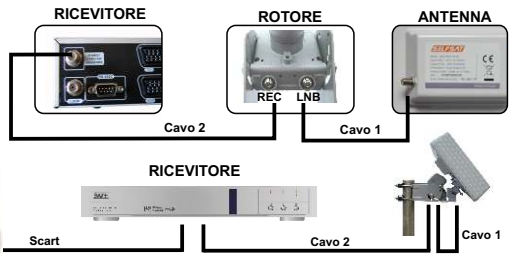

**Caratteristiche cavo coassiale**

**LUNGHEZZA: FINO A 30 m**

**LUNGHEZZA: DA 30 m A 60 m**

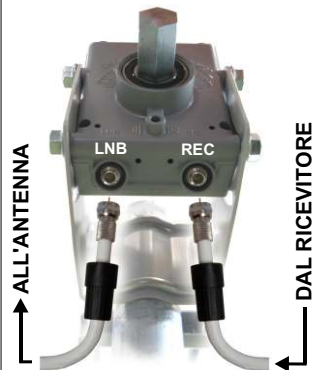

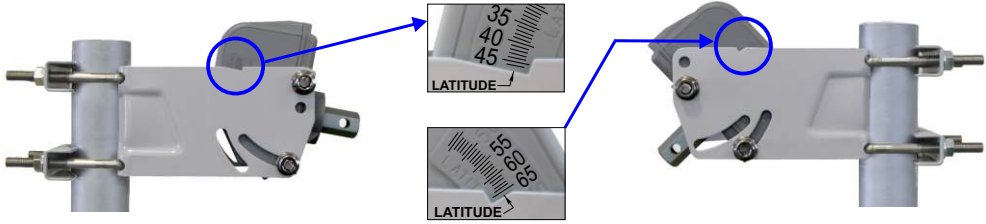
**4****LATITUDINE DA 10° A 45°****LATITUDINE DA 45° A 70°**

Regolare l'inclinazione del rotore con la vostra **LATITUDINE** ricavata dalle mappe alle pagine 27-35 o fornito dal sito [www.usals.info](http://www.usals.info) e stringere le viti di fissaggio con la chiave da 13 mm.

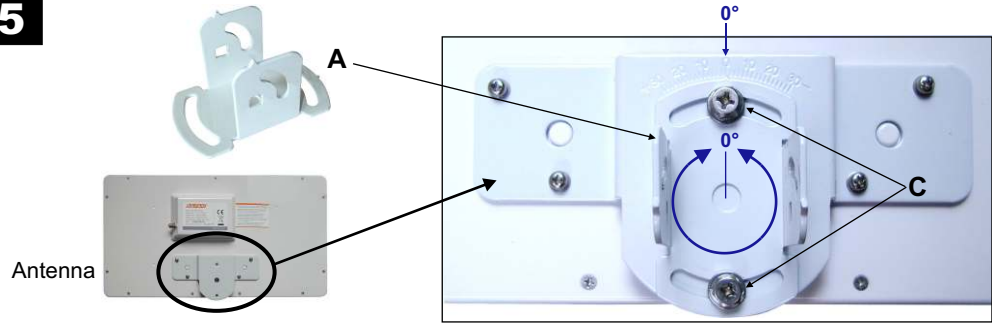
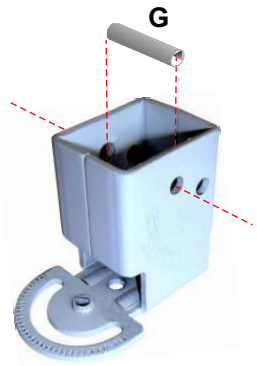
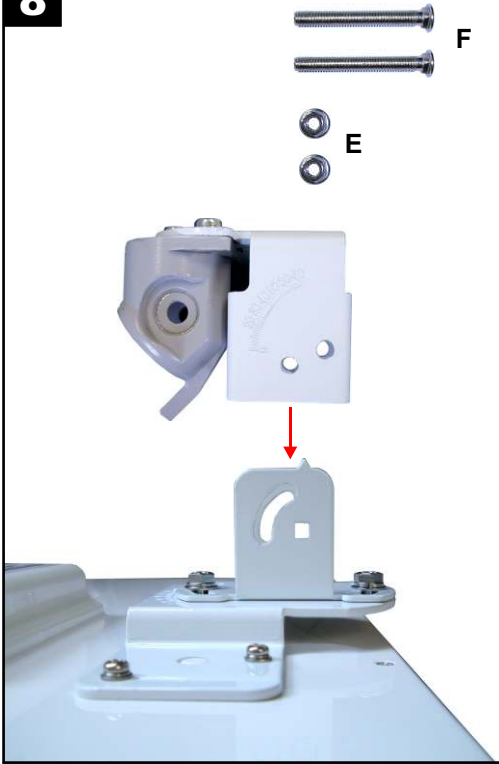
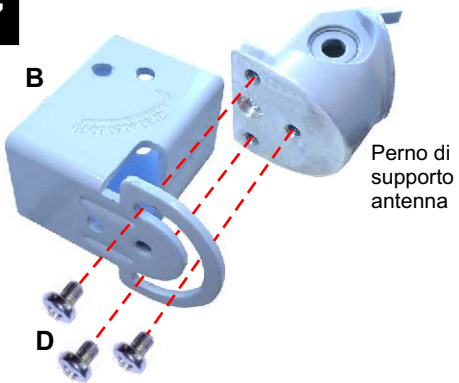
**5****ITALIANO****6****8****7**

- 9** Regolare l'inclinazione dell'antenna con il valore di **ELEVAZIONE ANTENNA** ricavato dalle mappe alle pagine 27-35.  
Se utilizzate il valore ricevuto tramite il sito [www.stab-usals.us](http://www.stab-usals.us), dovete sommare 3 gradi al valore di elevazione per il motore HH90:

**Esempio: ROMA**  
**Elevazione (HH90)= 38,5°**

Il valore da impostare sulla scala graduata è:

$$38,5 + 3 = 41,5°$$

Stringere le viti.

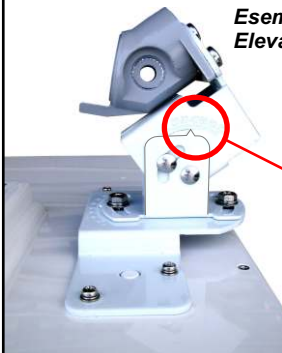

**8**

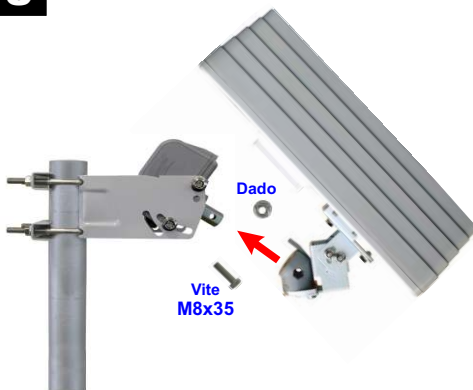

Inserire il perno mobile montato sull'antenna nel motore e fissarlo con la vite in dotazione.

- 10** - Consultare il manuale d'istruzioni del ricevitore e scegliere l'installazione in modalità USALS®.

#### Antenna setup

HotBird 13E	Motor Setting	USALS
(1) 10,719 GHz	Move	Stop
Vertical - 14V	Go to Reference	Go to 0
27,500MSPS	My Longitude	012,5 E
Tuner Lock	My Latitude	41,9 N
FEC 3/4		
Level		
Quality		

USALS positioner in use

- Scegliere un satellite più vicino al vostro SUD (se siete nell'emisfero NORD) o NORD (se siete nell'emisfero SUD).

**ES: ROMA, LONGITUDINE 12,5°E**  
**Satellite più vicino, HOTBIRD 13,0°E**

- Inserire nel menù del ricevitore i dati di **LATITUDINE** e **LONGITUDINE** forniti precedentemente dal sito: [www.stab-usals.us](http://www.stab-usals.us) o ricavati dalle mappe di pagg. 27-35

**ES: ROMA, LATITUDINE 41,9°N**  
**LONGITUDINE 12,5°E**

Alla conferma dei dati inseriti, il ricevitore manda il comando al rotore di spostarsi alla posizione calcolata.

**11**



Allentare le viti di fissaggio al palo di supporto. Ruotare tutto il sistema molto lentamente in senso orario od antiorario fino ad ottenere la massima **qualità del segnale**.

**12**

#### Antenna setup

HotBird 13E	Motor Setting	USALS
(1) 10,719 GHz	Move	Stop
Vertical - 14V	Go to Reference	Go to 0
27,500MSPS	My Longitude	012,5 E
Tuner Lock	My Latitude	41,9 N
FEC 3/4		
Level	87%	
Quality	76%	

USALS positioner in use

Quando la **qualità del segnale** raggiunge il valore massimo, stringere le viti di fissaggio del rotore al palo di sostegno.  
L'installazione è completata.



## Avvertenze

- Solo uno specialista vi può garantire una corretta installazione meccanica, che possa evitare danni o infortuni gravi.
- Il motore non può essere montato capovolto.
- Per il montaggio si devono impiegare tutte le viti e dadi contenuti nel kit. La mancanza di un dado o vite può essere causa d'instabilità o caduta del sistema.
- Il motore è stato collaudato per resistere in condizioni di vento pari a 140 Km/h con un disco da 100 cm, pertanto si dovrà avere molta cura nella scelta del palo di sostegno e del suo ancoraggio. Se possibile eseguire l'installazione in luogo riparato dal vento (i tetti delle case sono sconsigliati).
- L'impiego di dischi con diametro superiore a quello indicato nelle specifiche del motore è severamente proibito.
- Il motore, essendo un organo meccanico che ruota, deve essere installato fuori della portata delle persone.
- Il motore non può essere utilizzato per impieghi diversi da quelli indicati da STAB.
- Il motore è stato progettato per essere alimentato da un ricevitore sat o da un posizionatore STAB; qualsiasi altro sistema di alimentazione è severamente proibito e può causare danni o infortuni gravi.
- Alcuni ricevitori hanno il sistema antidisturbo collegato alla massa del connettore F. Questo può provocare una leggera scossa elettrica non pericolosa per l'utente. In condizioni particolari ( es. su un tetto o una scala) può essere causa di cadute o infortuni. Ogni volta che si interviene sul motore si deve perciò scollegare il ricevitore dalla presa di corrente.

## Certificato di garanzia

Questo apparecchio è fabbricato e controllato presso il nostro laboratorio con grande cura ed è coperto da garanzia di 36 mesi dalla data di acquisto .

Lo scontrino fiscale (o fattura) costituiscono documento di garanzia e dovranno essere allegati in copia all'apparecchiatura in caso di ritorno. La garanzia copre tutti i difetti dovuti ad un vizio di funzionamento o da un difetto di fabbricazione. La garanzia non copre l'apparecchio da cadute accidentali, cattivo uso o da ossidazioni dovute ad umidità per installazione errata. Tutti gli interventi sull'apparecchio eseguiti da personale non autorizzato faranno automaticamente decadere la garanzia.

**PREGHIAMO DI ANNOTARE IL NUMERO DI SERIE DEL MOTORE, QUESTO SEMPLIFICHERA' EVENTUALI SERVIZI POST-VENDITA O ASSISTENZA TECNICA.**

**NUMERO DI SERIE**

--	--	--	--	--	--	--	--	--	--

## Informazioni

Per chiarimenti ed informazioni sull'installazione ed uso rivolgersi al vostro rivenditore locale oppure a:

IDOIT  
Midi France Distribution ZA de Fontvieille Route des 4 Saisons

13190 ALLAUCH - FRANCE

Tel: +33 - (0)4 91 07 50 50

[selfsat@mfdis.com](mailto:selfsat@mfdis.com)

**Nous garantissons la compatibilité et le parfait fonctionnement en mode USALS uniquement avec les récepteurs qui possèdent le logo :**



## Caractéristiques Techniques

Protocole de communication	Niveau DiSEqC1.2 <sup>®</sup>	Température d'utilisation	-40 °C + 80 °C
Diamètre maximum d'antenne	95 cm	Humidité maximum	100%
Poids maximum d'antenne	10 kg	Positions programmables (DiSEqC1.2 <sup>®</sup> )	49 satellites
Diamètre du support pour mât	ø (35 à 68) mm	Positions pré-programmées (DiSEqC1.2 <sup>®</sup> )	28 satellites
Longueur du support mobile	145 mm	Positions programmables (USALS <sup>®</sup> )	pas de limites
Diamètre du support d'antenne	ø 42 mm	Connecteurs	Type F
Angle de rotation	±65°	Type de connexion	Câble coaxial
Vitesse de rotation	2,4°/s (18V) 1,5°/s (13V)	Limites mécaniques	±72°
Alimentation	13/18 Vdc	Limites électroniques programmables	de 5° à 65°
Consommation en mode stand by	40 mA	Rotation lente	à impulsions de 0,1°
Consommation pendant le mouvement	180 mA	Inclinaison	de 10° à 70°
Consommation au départ du mouvement (MAX)	350	Poids du rotor	2,6 kg

## Accessoires de montage du moteur

1 Support de fixation au mât



2 Cavaliers U

2 Mors



1 Clef (13mm)



1 Support d'antenne



2 Connecteurs mâle F



8 écrous (8 MA)



1 écrou +  
1 boulon 8 MA  
(pour le montage du support d'antenne)



2 Couvres connecteurs



2 Tiges filetées



## Accessoires de montage de l'antenne



A - 1

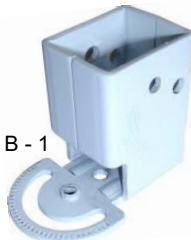

B - 1

C - 2



D - 3



E - 2



F - 2



G - 1



## Antenne

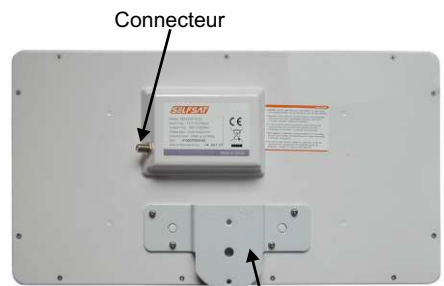

Connecteur

Support de fixation du moteur

La procédure d'installation en mode USALS® est très simple. Si vous ne connaissez pas les coordonnées de votre lieu d'installation (longitude et latitude), nous vous invitons à consulter notre site [www.stab-usals.us](http://www.stab-usals.us) ou les cartes pages 27-35 de ce manuel (demander à la mairie de votre lieu de résidence ou à votre fournisseur). La société STAB sera heureuse de vous aider et vous fournira toutes les données : **Latitude**, **Longitude**, **élévation de l'antenne**.

**1**

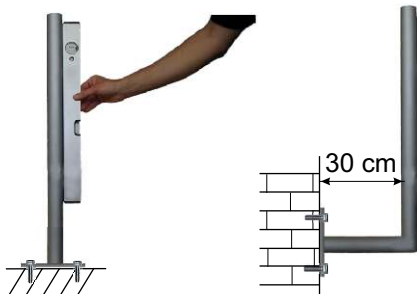

Afin d'obtenir un pointage correct des satellites, le mât de support doit être rigoureusement vertical (utiliser un fil à plomb si besoin).

**2**

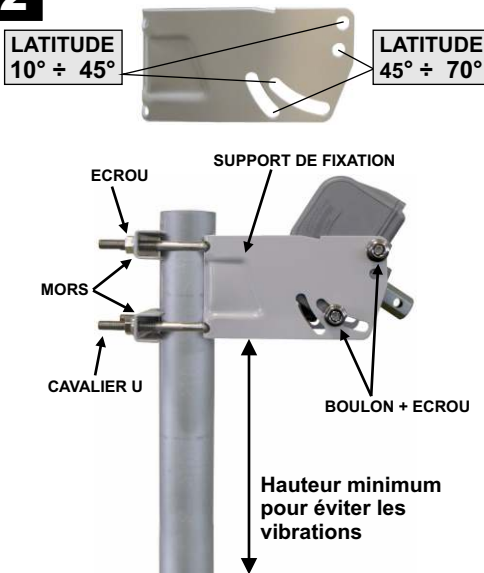

FRANÇAIS

**3**

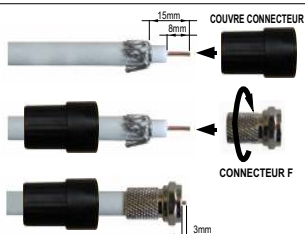

- Monter 2 fiches F sur un câble coaxial d'environ 1,5 m (Câble 1)
- connecter la fiche F qui va du LNB au moteur (sortie moteur LNB).
- Monter 2 connecteurs F sur le câble de descente et connecter la sortie REC du rotor à votre récepteur (câble 2).

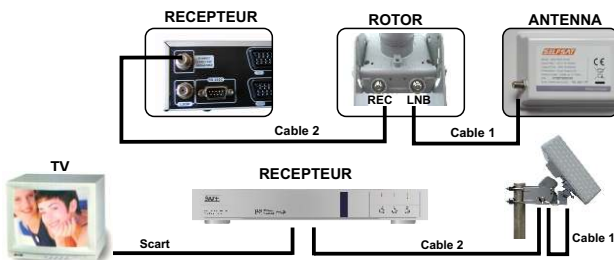
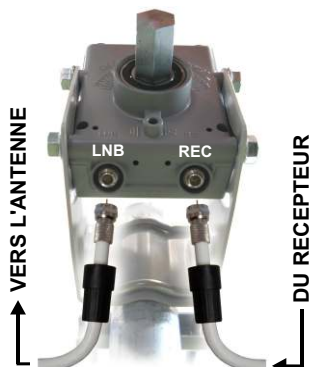

**Caractéristiques du câble coaxial**

**Longueur: de 30**

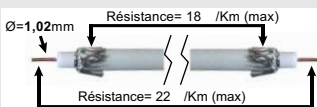

**Longueur : de 30m à 60m**

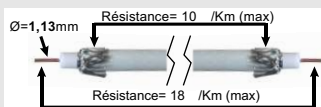

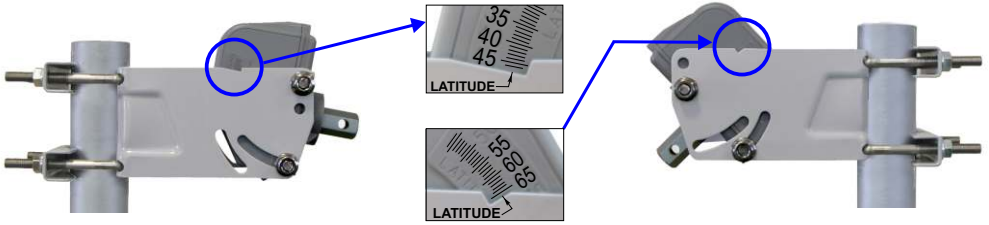
**4****LATITUDE DE 10° A 45°****LATITUDE DE 45° A 70°**

Ajuster l'inclinaison du moteur (latitude du lieu d'installation) et serrer les écrous de tige filetée et les boulons.

**5**

Antenna

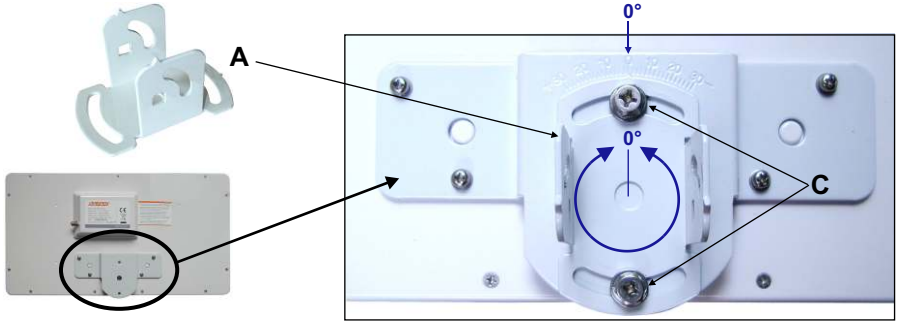
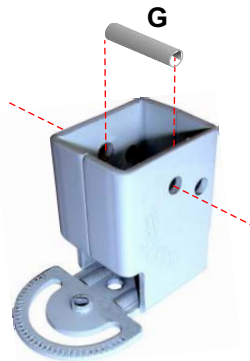
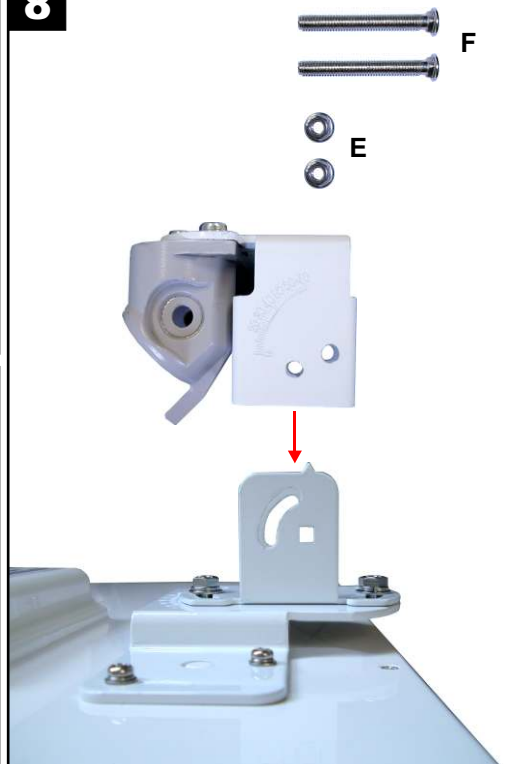
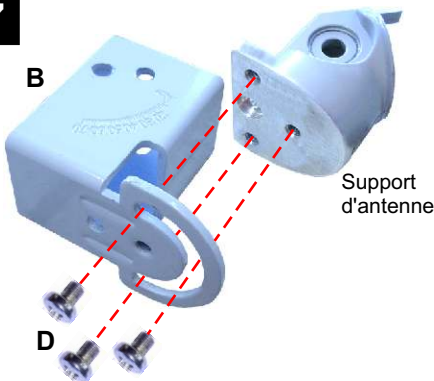
**6****8****7****B**Support  
d'antenne**D**

## 9 Ajuster l'inclinaison de l'antenne selon la valeur d'**ELEVATION ANTENNE** obtenue des cartes aux pages 27-35.

Si vous ajustez le moteur selon la valeur reçue par le site [www.stab-usa/s.us](http://www.stab-usa/s.us), vous devrez ajouter 3 degrés à la valeur d'élévation pour le moteur HH90.

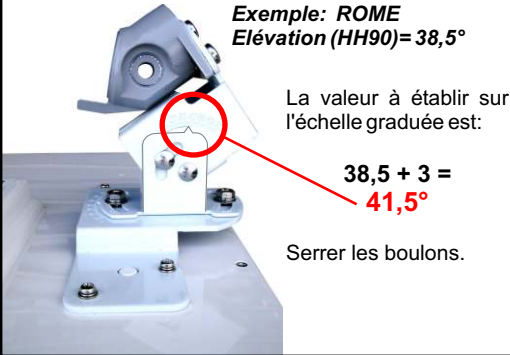

## 8

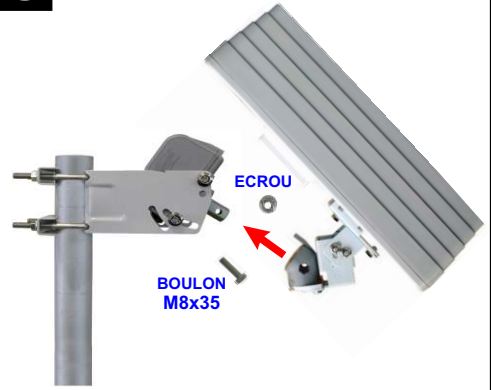

Monter l'ensemble support et antenne sur le moteur et serrer les écrous.

## 10

- Consulter le manuel d'instructions de votre récepteur et sélectionner le type d'installation en mode USALS®.

**Antenna setup**

HotBird 13E	Motor Setting	USALS
(1) 10,719 GHz	Move	Stop
Vertical - 14V	Go to Reference	Go to 0
27,500MSPS	My Longitude	012,5 E
Tuner Lock	My Latitude	41,9 N
FEC 3/4		
Level		
Quality		

**USALS positioner in use**

- Choisir un satellite situé au plus proche de votre direction sud (si vous êtes dans l'hémisphère nord) ou nord (si vous êtes dans l'hémisphère sud).

**EX: ROMA, LONGITUDE 12,5°E**  
**Satellite le plus proche, HOTBIRD 13,0°E**

- Remplir les espaces vides dans le menu de votre récepteur avec les valeurs de **Latitude** et de **Longitude**. Si ces valeurs sont correctes.

**EX: ROMA, LATITUDE 41,9°N**  
**LONGITUDE 12,5°E**

le récepteur pilotera le moteur vers la position souhaitée.

## 11



Attendre l'arrêt du moteur.  
 Tourner lentement l'ensemble antenne/moteur autour du mât vers la droite ou la gauche, vous obtiendrez une augmentation du niveau du signal et de la qualité de réception.

## 12

**Antenna setup**

HotBird 13E	Motor Setting	USALS
(1) 10,719 GHz	Move	Stop
Vertical - 14V	Go to Reference	Go to 0
27,500MSPS	My Longitude	012,5 E
Tuner Lock	My Latitude	41,9 N
FEC 3/4		
Level 87%		
Quality 76%		

**USALS positioner in use**

Lorsque la **qualité du signal** a atteint la valeur la plus haute, serrer les boulons de fixation au mât de support.

L'installation vient d'être achevée.

## ATTENTION! Informations importantes

- Seul un spécialiste est en mesure de garantir une installation mécanique permettant d'éviter des dommages, des risques et des problèmes importants.
- Le moteur ne doit en aucun cas être monté tête bêche.
- Pour un montage conforme et sans risque toutes les pièces (boulons, rondelles et écrous) fournis dans le kit de montage doivent être utilisés. Tout oubli peut être la cause d'instabilité ou de chute du système.
- Le moteur HH90 a été conçu pour tracter des antennes de 1 mètre par des vents de 140 kilomètres/heure (ces dimensions sont celles d'antennes offset dans le sens de la largeur), nous vous demandons, pour éviter les désagréments, d'être très attentif au choix:
  - du support de montage (extrême robustesse),
  - de la solidité, de la résistance du point d'encrage, ainsi que de la qualité des boulons utilisés.
  - de l'emplacement de l'installation (le plus à l'abri possible d'importantes rafales de vent. L'installation sur les toits fragiles est déconseillée).
- L'usage d'antennes de dimensions supérieures à celles indiquées dans les spécifications techniques de STAB est prohibé.
- Le moteur étant une pièce en mouvement, il doit impérativement être installé hors de la portée d'êtres vivants.
- Les moteurs ne doivent en aucun cas être utilisés pour d'autres usages que ceux prévus par STAB.
- Le moteur a été développé pour être alimenté par un récepteur satellite ou un positionneur STAB, tout autre système d'alimentation est formellement interdit et peut créer de graves dommages.
- Certains récepteurs satellites ont un système anti-parasites connecté à la masse du connecteur F. Ceci peut provoquer de légères secousses électriques sans danger pour l'utilisateur. Attention des chutes peuvent survenir à cause de l'utilisation d'échelle, ou par le fait de se trouver sur un toit ou dans des endroits dangereux. C'est pourquoi nous vous conseillons, pour chaque intervention directe sur le moteur, hors installation, de déconnecter les récepteurs satellites des prises de courant.

## Conditions de garantie

Ce produit est fabriqué avec beaucoup de soins et contrôlé dans notre usine. Il bénéficie d'une garantie de 36 mois à compter de sa date d'achat. La facture tient lieu de garantie. Une copie de celle-ci devra être jointe au moteur en cas de retour. La garantie couvre tout vis de fabrication ou de fonctionnement et non les chutes, l'utilisation non conforme et l'oxydation due à l'humidité. Toute intervention de SAV effectuée par un personnel non qualifié rend la garantie caduque.

**NOUS VOUS PRIONS D'INDIQUER IMPERATIVEMENT LE NUMERO DE SERIE DU MOTEUR AVEC TOUTE DEMANDE CONCERNANT LE SERVICE APRES VENTE.**

NUMERO DE SERIE

--	--	--	--	--	--	--	--	--	--

## Informations

Pour toutes informations complémentaires sur l'installation et l'utilisation de nos produits s'adresser à:

VOTRE DISTRIBUTEUR LOCAL ou:

IDOIT

Midi France Distribution ZA de Fontvieille Route des 4 Saisons

13190 ALLAUCH - FRANCE

Tel: +33 - (0)4 91 07 50 50

selfsat@mfdis.com

Garantizamos una completa compatibilidad y un trabajo perfecto en modo USALS sólo con receptores que lleven este logotipo:



## Datos Técnicos

Protocolo de Comunicación	DiSEqC1.2 <sup>®</sup>	Temperatura de Trabajo	-40°C +80°C
Diámetro máximo del plato	95 cm	Humedad Máxima relativa	100%
Máximo Peso del Plato	10 kg	Posiciones Programables (DiSEqC1.2 <sup>®</sup> )	49 satélites
Diámetro del Eje de Soporte	∅ (35 a 68) mm	Posiciones Preprogramadas (DiSEqC1.2 <sup>®</sup> )	28 satélites
Longitud del Soporte del Plato	145 mm	Posiciones Programables (USALS <sup>®</sup> )	no límites
Diámetro del Soporte del Plato	∅ 42 mm	Conectores	Tipo F
Ángulo de rotación	±65°	Conexión	Cable Coaxial
Velocidad de rotación	2,4°/s (18V) 1,5°/s (13V)	Límites Mecánicos	±72°
Tensión de Alimentación de trabajo	13/18 Vdc	Límites Eléctricos Programables	de 5° a 65°
Consumo en modo de reposo	40 mA	Rotación Fina	impulsos de 0,1°
Consumo en modo operación	180 mA	Inclinación del eje del rotor	de 10° a 70°
Consumo máximo de inicio de movimiento	350 mA	Peso del Rotor	2,6 kg

## Accesorios para el montaje del motor

1 Ud. Abrazadera para fijarlo al mástil



2 Uds. Espárragos roscados en U

2 Uds. Pinzas



1 llave (13mm)



1 Soporte del plato



2 Uds. Conectores F macho



8 Uds. Tuercas (8 MA)



1 Ud. Tuerca +  
1 Ud. Tornillo 8 MA  
(para el montaje del soporte del plato)

2 Uds. Cubiertas para conectores



2 Uds. Tornillos



## Accesorios para el montaje de la antena



A - 1



B - 1

C - 2



D - 3



E - 2



F - 2



G - 1



## Antena



Conector

Abrazadera para fijar el rotor



El procedimiento de instalación de USALS® es sumamente simple. Si usted no está completamente seguro de las coordenadas y los grados de elevación de la antena para su situación de la instalación, consulte el sitio: [www.stab-usals.us](http://www.stab-usals.us) o los mapas de las páginas 27-35.

STAB le proporcionará todos los datos de: **Latitud**, **Longitud**, **Elevación de la Antena**.

**1**

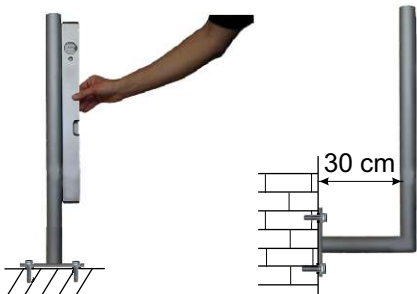

Para obtener una alineación correcta a los satélites, todos los sistemas deben estar en una línea de plomada perfecta.

**2**

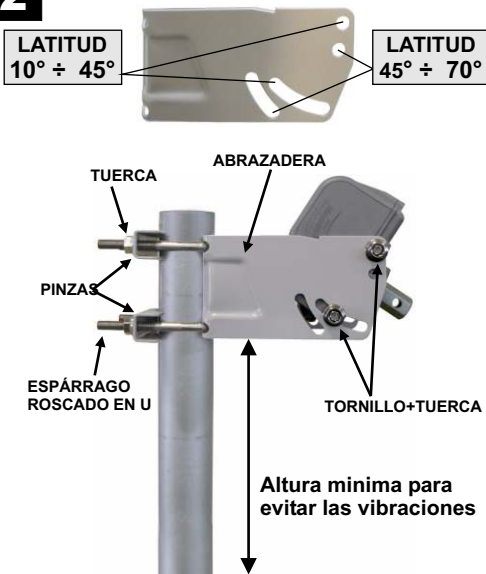

**3**

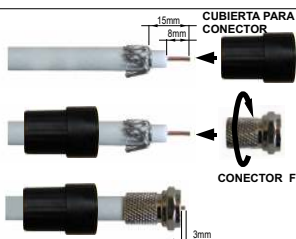

- En un trozo de cable coaxial de aproximadamente 1,5m de largo.
- conecte un extremo al LNB y el otro al conector marcado como LNB del rotor.
- Encaje un conector F en cada extremo del cable que va al receptor y conéctelo al conector REC del rotor y el otro al receptor.

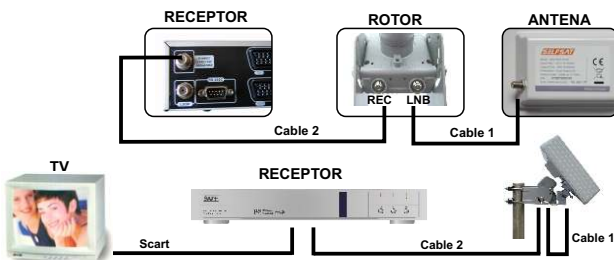
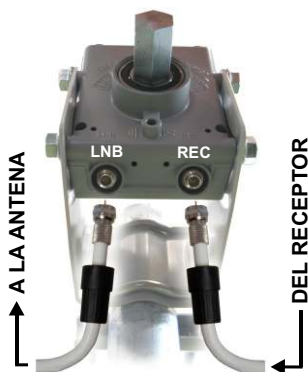

### Características del cable coaxial

**Longitud: hasta 30 m**

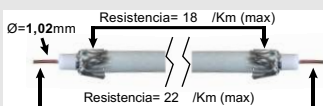

**Longitud: de 30 m a 60 m**

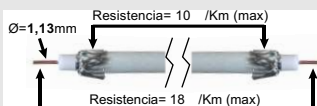

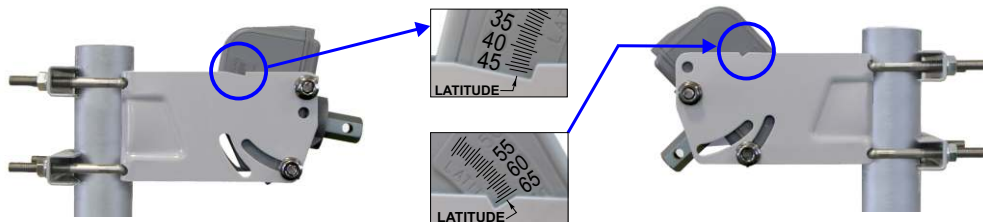
**4****LATITUD DE 10° A 45°****LATITUD DE 45° A 70°**

Ajuste la inclinación del rotor a su **Latitud** y apriete los tornillos y las tuercas de fijación con la llave de 13mm.

**5**

Antena

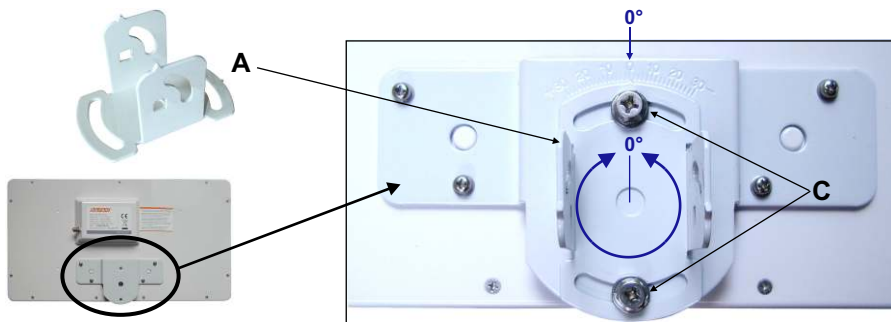
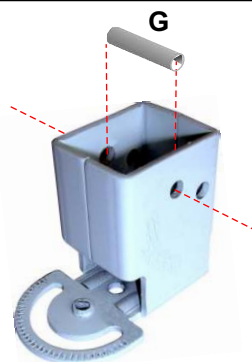
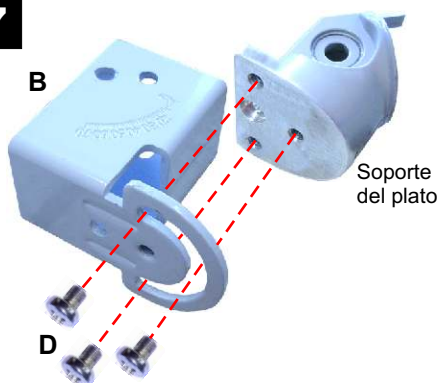
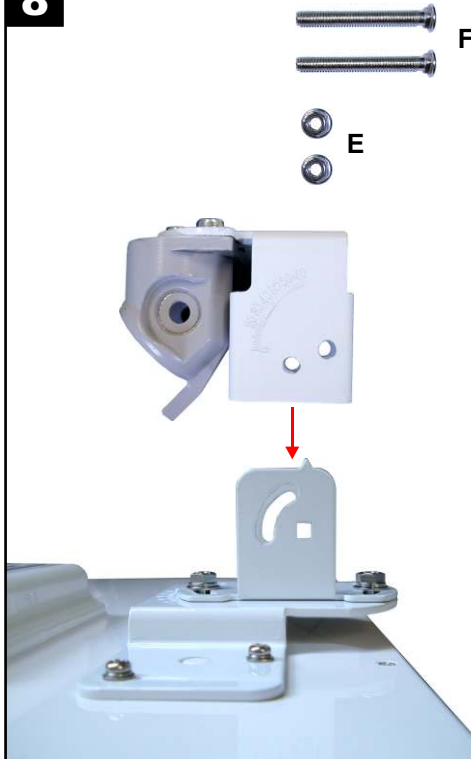
**6****7****8**

**9** Ajuste la inclinación del plato con el valor de **Elevación del plato** obtenido por los mapas en páginas 27-35.  
Si use el valor obtenido por el sitio [www.stab-usals.us](http://www.stab-usals.us), tiene que sumar 3 grados al valor de elevación del motor HH90:

**Ejemplo: ROMA**  
**Elevación (HH90) = 38,5°**

Ajuste la inclinación con el valor:

$$38,5 + 3 = 41,5^\circ$$

Apriete los tornillos.

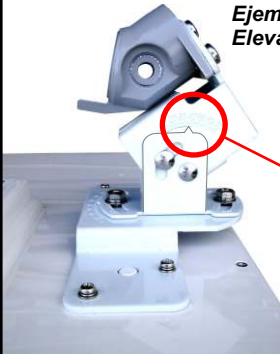

**8**

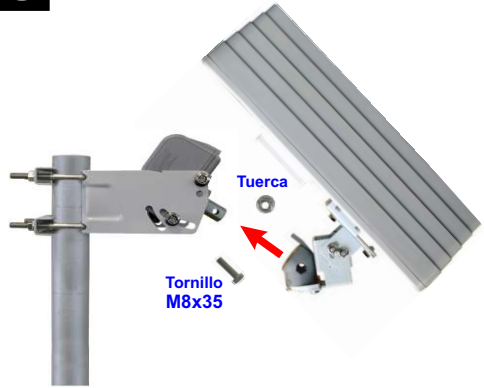

Inserte el tubo en el motor en la posición apropiada y fíjelo con el tornillo y la tuerca suministrada.

**10** - Vea el manual de las instrucciones de su receptor y seleccione el tipo de instalación en el modo de USALS®.

**Antenna setup**

HotBird 13E	Motor Setting	USALS
(1) 10,719 GHz	Move	Stop
Vertical - 14V	Go to Reference	Go to 0
27,500MSPS	My Longitude	012,5 E
Tuner Lock	My Latitude	41,9 N
FEC 3/4		
Level		
Quality		

USALS positioner in use

- Escoja el satélite más cercano a su Sur (si usted se encuentra en el hemisferio Norte) o a su Norte (si usted se encuentra en el hemisferio Sur).

**EJEMPLO: ROMA, LONGITUD 12,5°E**  
**satélite más cercano, HOTBIRD 13,0°E**

- Rellene los espacios vacíos en el menú del receptor con los valores de la **Latitud** y la **Longitud** previamente obtenidos por el sitio web [www.stab-usals.us](http://www.stab-usals.us) o por los mapas en páginas 27-35

**EJEMPLO: ROMA, LATITUD 41,9°N**  
**LONGITUD 12,5°E**

Cuando los valores se han introducido correctamente, el receptor moverá el motor a la posición calculada.

**11**



Espere hasta que el motor se pare.  
Mueva ligeramente en sentido horario o en sentido anti-horario el conjunto de plato y motor hasta que usted encuentre una imagen en la pantalla de la televisión conectada al receptor.

**12**

**Antenna setup**

HotBird 13E	Motor Setting	USALS
(1) 10,719 GHz	Move	Stop
Vertical - 14V	Go to Reference	Go to 0
27,500MSPS	My Longitude	012,5 E
Tuner Lock	My Latitude	41,9 N
FEC 3/4		
Level	87%	
Quality	76%	

USALS positioner in use

Cuando la calidad de la señal alcanza el máximo valor, apriete los tornillos de fijación del rotor al mástil.  
La instalación ha sido completada.

## Advertencias

- Sólo un especialista puede garantizarle una instalación mecánica correcta que evitará daños o lesiones serias.
- El motor no debe montarse nunca al revés.
- En el montaje, deben usarse todos los tornillos y tuercas contenidas en el equipo. La ausencia de un tornillo o tuerca puede causar inestabilidad o el fallo del equipo.
- El motor se ha probado para resistir unas condiciones de viento de 140 Km/h con un plato de 100 cm, por eso debe tener el cuidado de escoger un mástil de apoyo y su anclaje. Si posible, la instalación debe llevarse a cabo en un lugar albergado del viento (las azoteas nunca son aconsejables).
- Se prohíbe estrictamente el uso de platos con un diámetro más grande de los indicados en las especificaciones para cada motor.
- El motor, ya que es un instrumento con movimiento mecánico, debe instalarse fuera de alcance de las personas.
- El motor no debe usarse para otros propósitos que aquellos indicados por STAB.
- El motor se ha diseñado para ser utilizado con un receptor de satélite o por un posicionador de STAB, cualquier otro tipo de suministro está prohibido estrictamente y puede causar daños o lesiones serias.
- Algunos receptores tienen un sistema de anti-perturbación unido al cuerpo del conector F. Esto puede provocar un choque eléctrico ligero no peligroso para el usuario. En condiciones particulares (por ejemplo en un tejado o en una escalera) puede causar caídas o lesiones. Cada vez que se tenga que manipular el motor el receptor debe ser desconectado de la toma de corriente.

## Condiciones de garantía

Este rotor se ha fabricado y probado por nuestro laboratorio con extremo cuidado y lleva una garantía durante 36 meses de la fecha de la compra. Debe enviar junto con el equipo cuando lo devuelva una copia del recibo de la tienda o de la factura junto con el documento de la garantía. Esta garantía cubre todos los defectos de fabricación y los fallos de trabajo, pero excluye todos los daños y perjuicios causados por caídas, uso incorrecto u oxidaciones externas debido a la instalación incorrecta. Cualquier reparación hecha por personal no autorizado cancelará esta garantía automáticamente.

**ANOTE POR FAVOR EL NÚMERO DE SERIE DEL MOTOR PARA FACILITAR UN EVENTUAL SERVICIO DE ASISTENCIA TÉCNICA.**

**NÚMERO DE SERIE**

--	--	--	--	--	--	--	--	--	--

## Informaciones

Para una información más extensa y consejos sobre la instalación y contacto durante el uso:

**SU DISTRIBUIDOR LOCAL** o:

IDOIT

Midi France Distribution ZA de Fontvieille Route des 4 Saisons

13190 ALLAUCH - FRANCE

Tel: +33 - (0)4 91 07 50 50

[selsat@mfdis.com](mailto:selsat@mfdis.com)

**NORWAY, SWEDEN, FINLAND, DENMARK, BALTIC REPUBLICS**

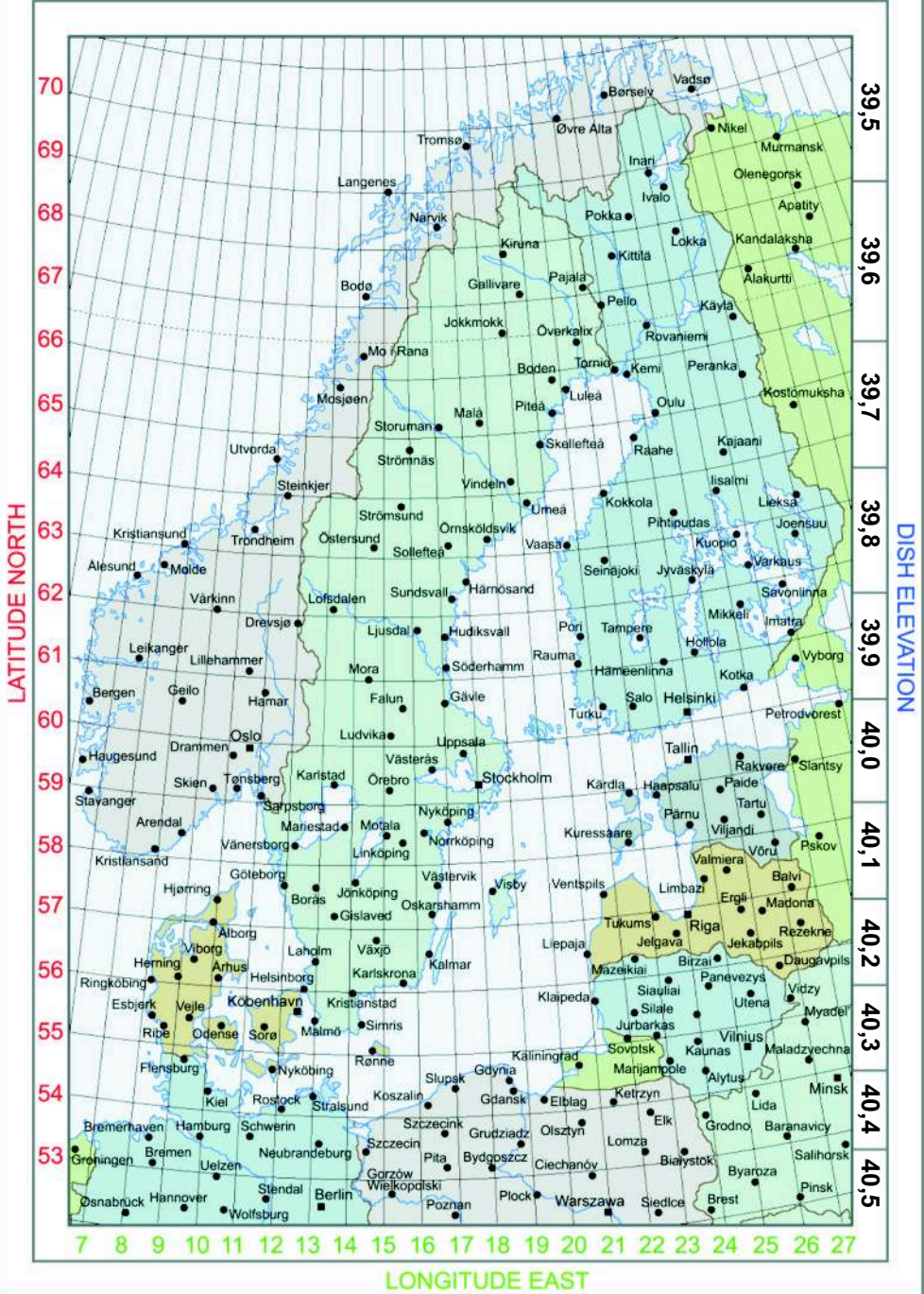



**UK and EIRE**

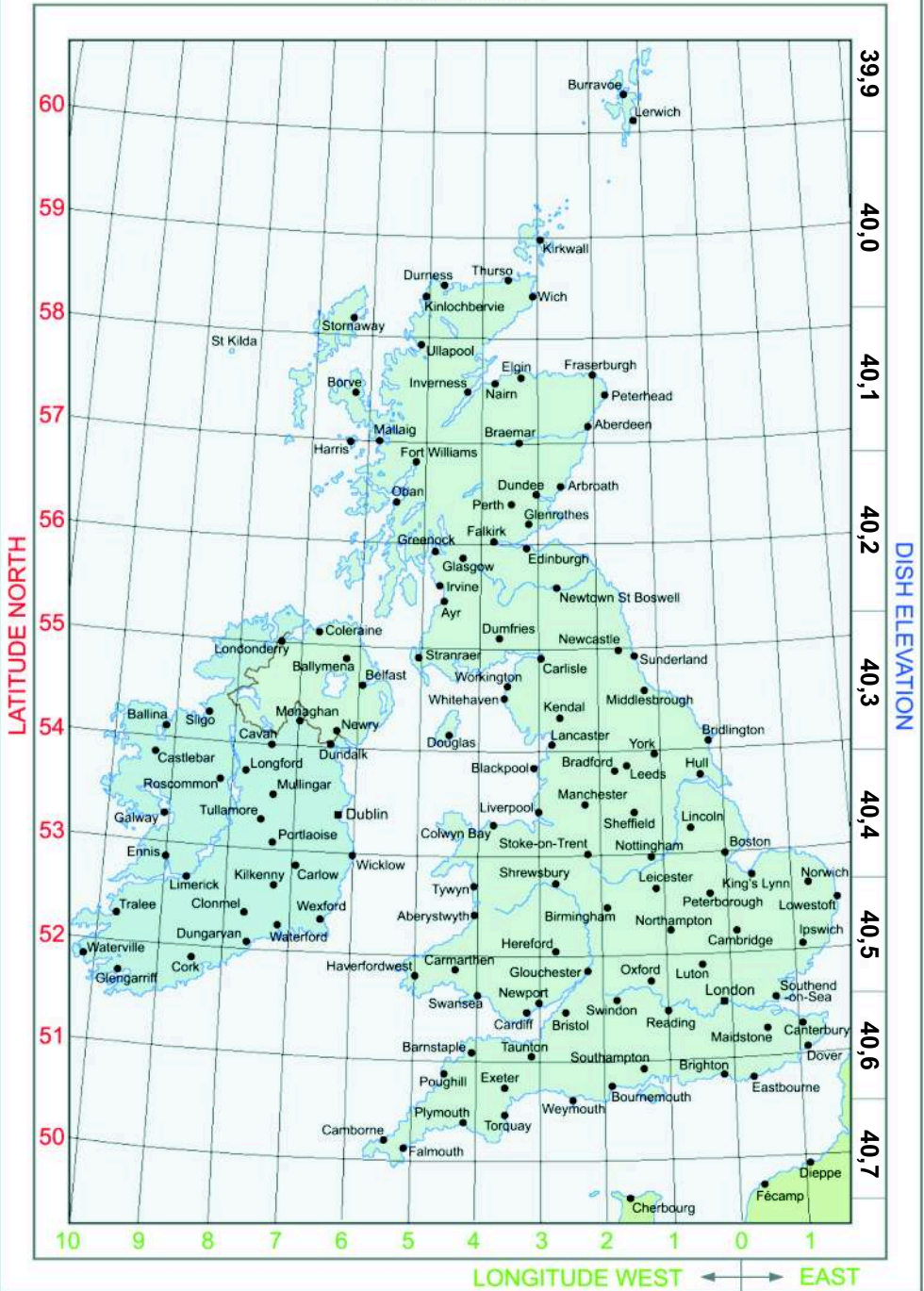

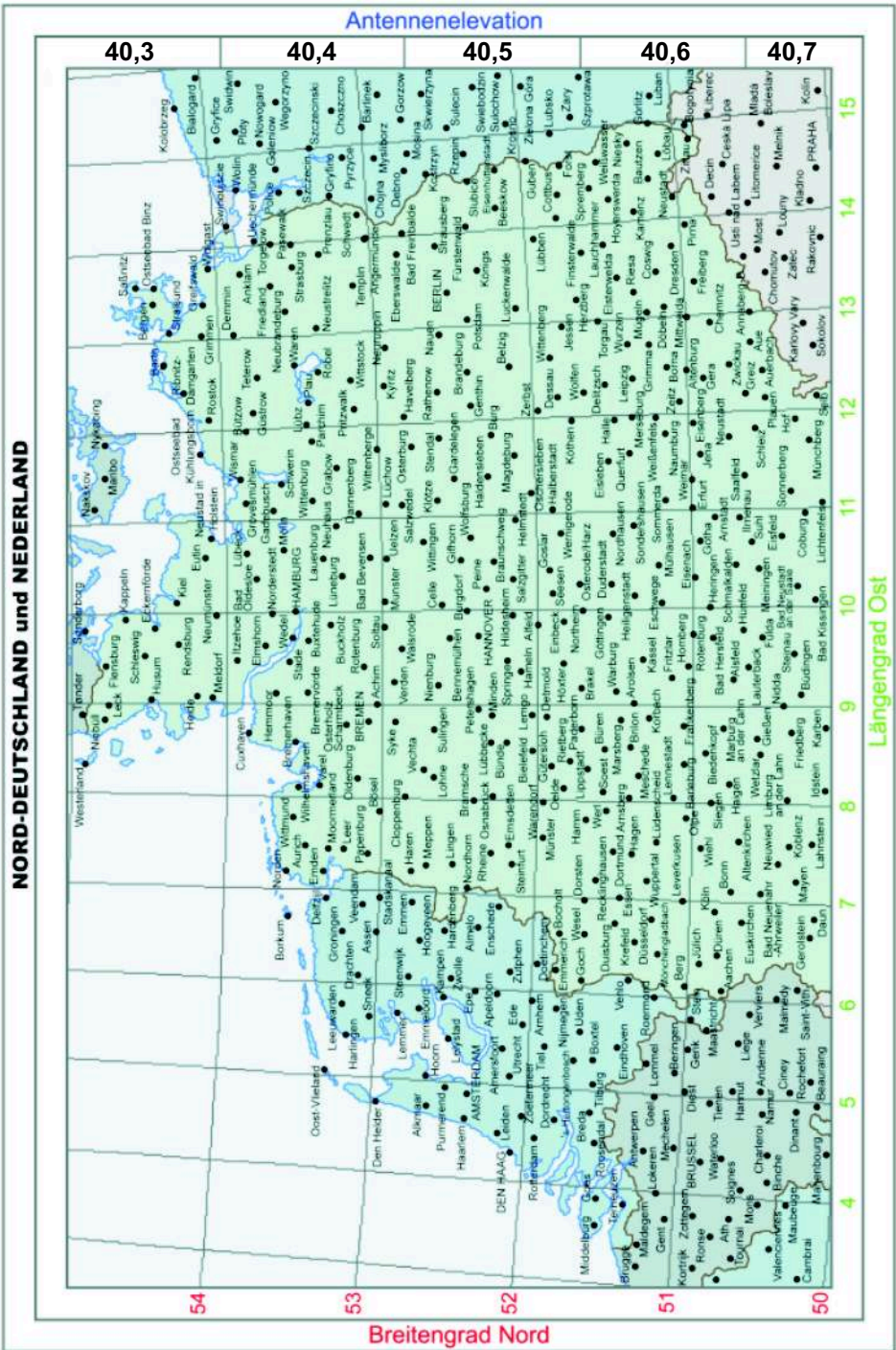



SÜD-DEUTSCHLAND, ÖSTERREICH, SCHWEIZ und SLOVENIJA

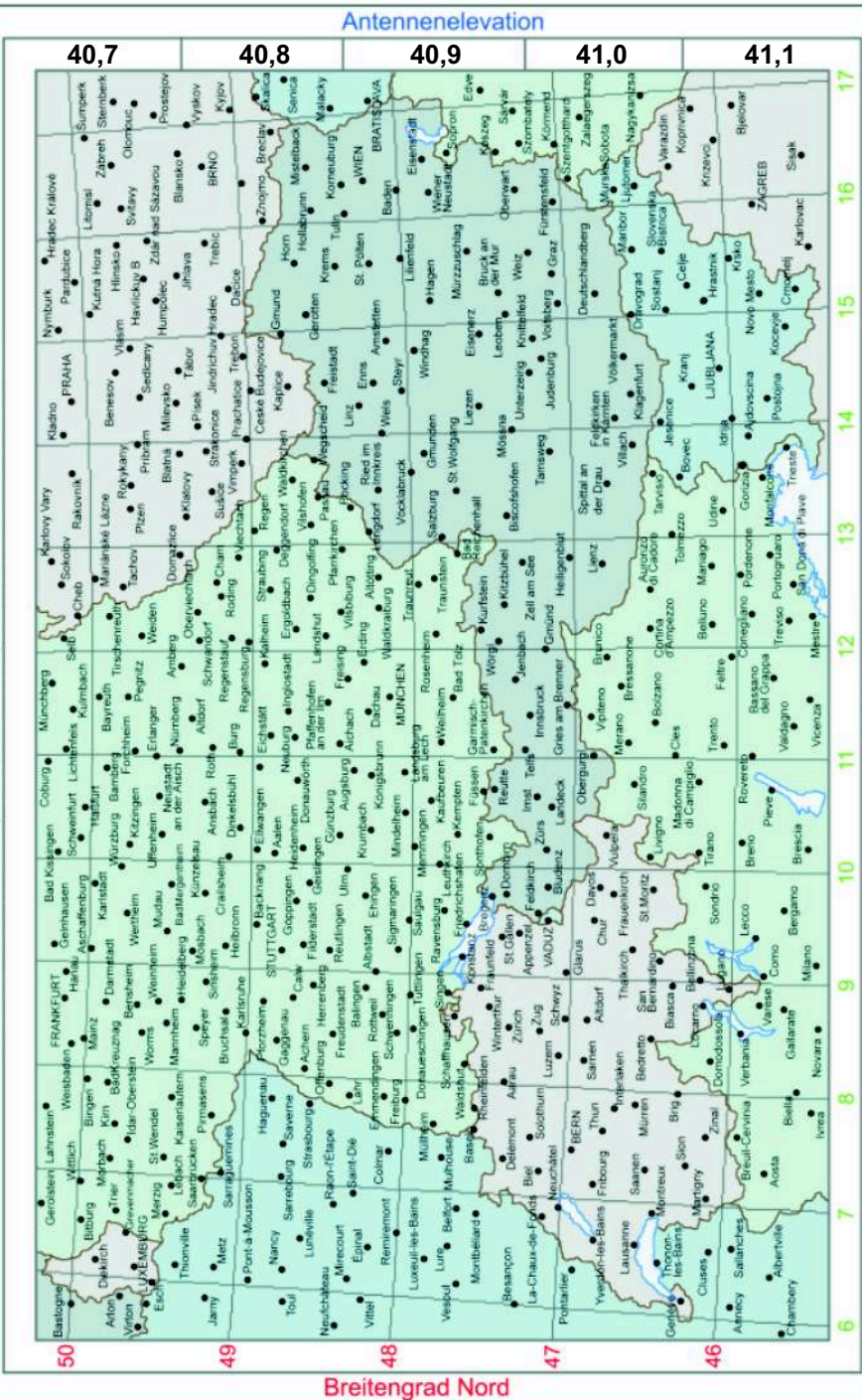





ELEVACION DEL PLATO

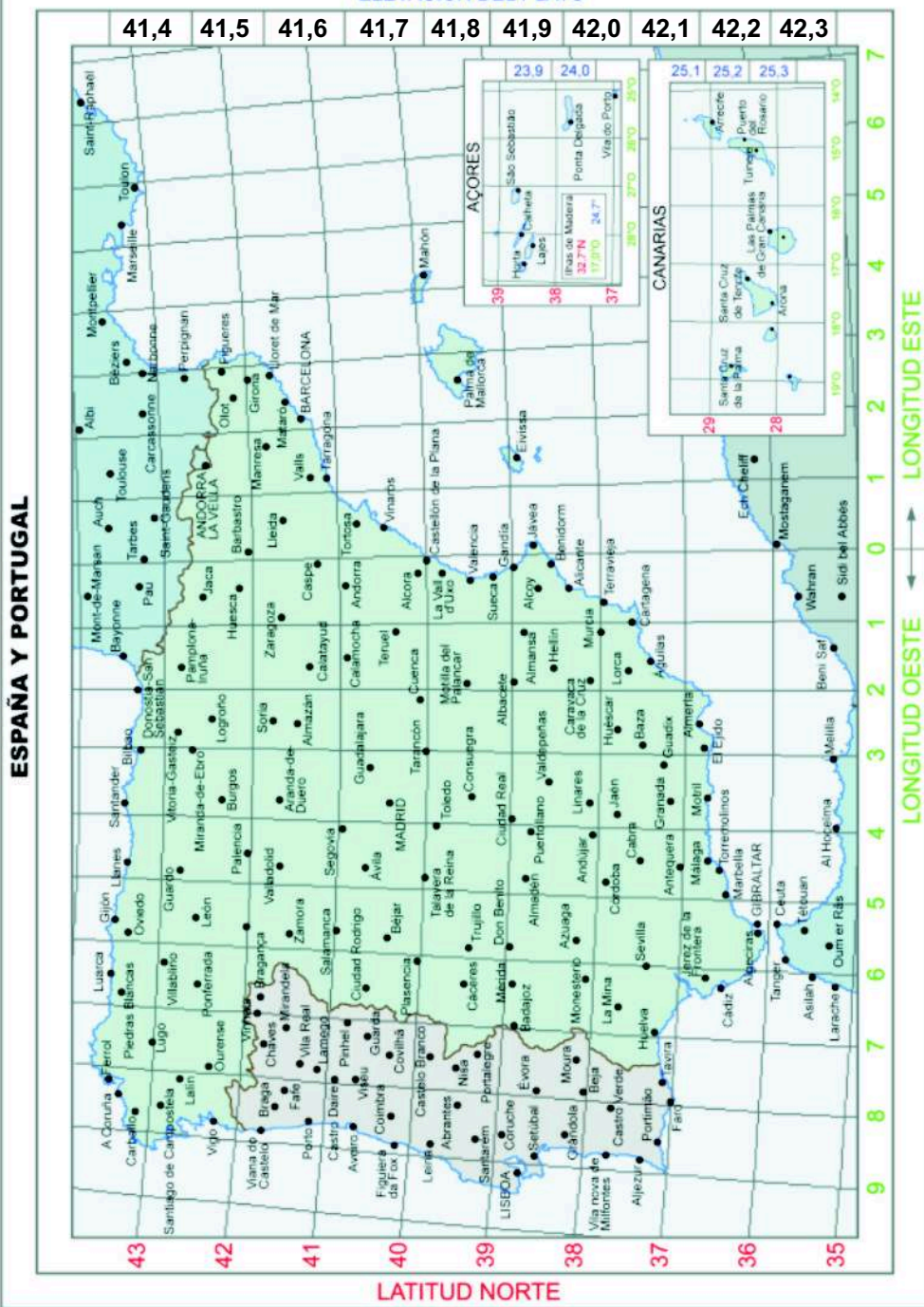

ESPAÑA Y PORTUGAL

ITALIA - NORD

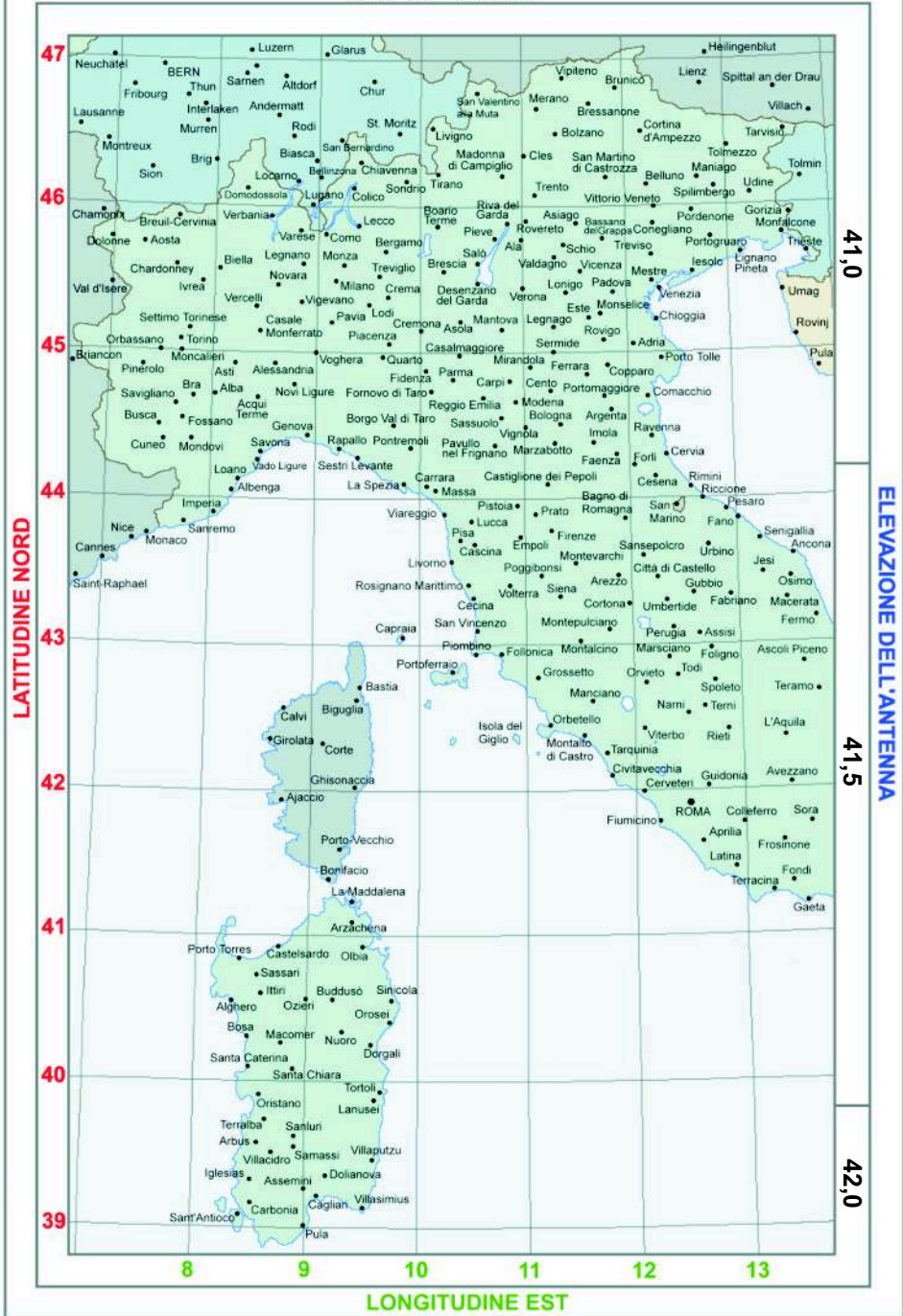





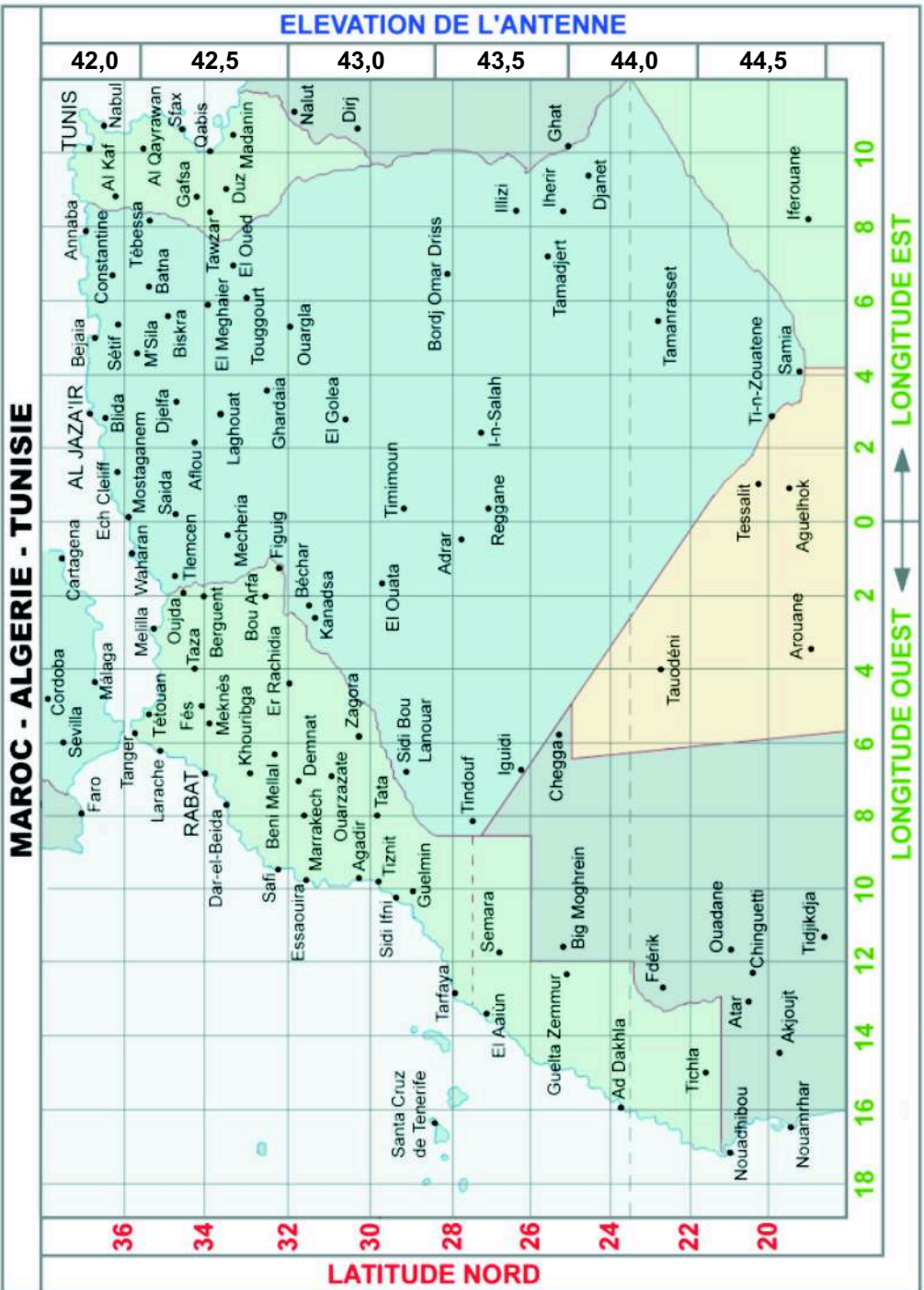



[www.self-sat.com](http://www.self-sat.com)